

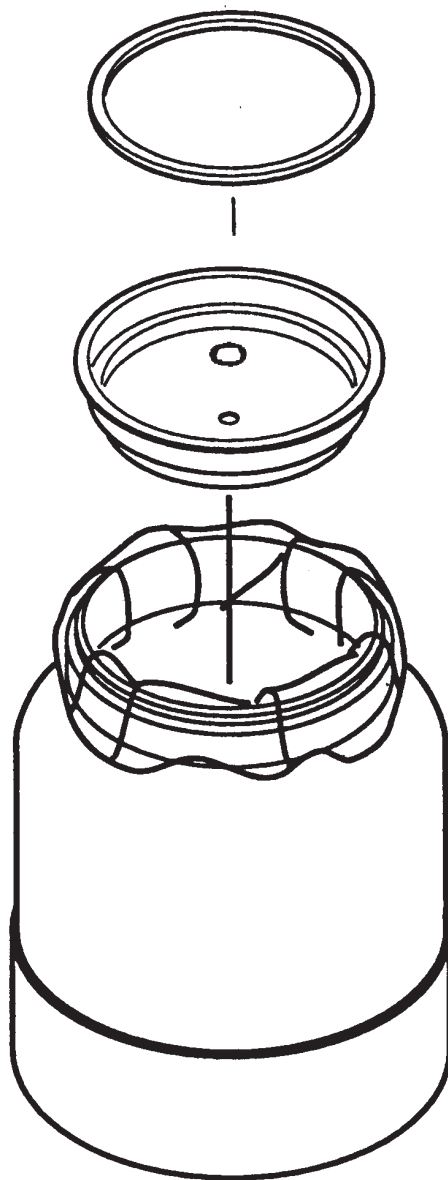

KK-5051 DISPOSABLE KB II CUP LINER



IMPORTANT: Read and follow all instructions and SAFETY PRECAUTIONS on Pages 1 and 4 before using this equipment. Retain for future reference.

KK-5051 Disposable Cup Liner Kit Includes:

20 liners
20 lids
3 rings

DESCRIPTION



WARNING

Halogenated hydrocarbon solvents - for example: 1,1,1, - trichloroethane and methylene chloride - can chemically react with aluminum parts and components and cause an explosion hazard. Read the label or data sheet for the material. Do not use materials containing these solvents with the aluminum KB-555 cup. Stainless steel model KB-545-SS may be used with halogenated solvents.



WARNING

Static electricity is produced when using an equipment cleaner. Static electricity sparks may be created during the cleaning operation. A spark from static electricity may cause fire or explosion. If the gun or tool attached to the fluid hose line is not grounded, it will build a static charge. To prevent sparks from static electricity, you must ground:

1. The Hose/Gun Cleaner.
2. The gun or tool attached to the fluid hose line from the Hose/Gun Cleaner.
3. The waste container.

To ground equipment:

1. Use conductive air hose.
2. Attach one end of a ground wire to each item listed above.
3. Attach the other end of the ground wire to a water pipe, metal electrical conduit or any pipe or structural member known to be grounded.

The DeVilbiss liner system is intended for use in a KB II pressure cup. The liner creates a barrier so the coating cannot contact the cup or lid. The liner can be used with any material that is compatible with polyethylene. The only wetted cup part is the fluid tube which is either stainless steel or aluminum.

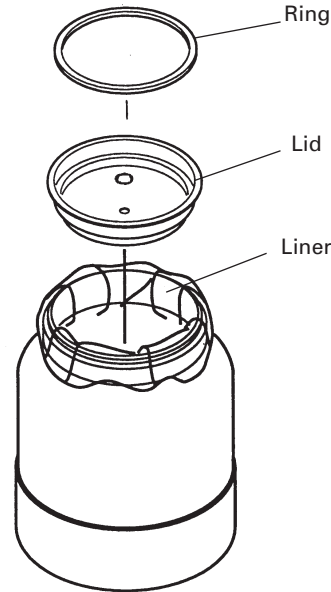

Figure 1

*KK-5052 Solvent Saver Attachment Kit Includes:
HD-410 Adapter Fitting Assembly
2' Hose Assembly

Recommended Replacement of Fluid Tube for KB II Cup:

*KK-4996 Stainless Steel
*KK-4997 Aluminum

*Order separately.

SAFETY PRECAUTIONS

This manual contains important information that all users should know and understand before using the equipment. This information relates to USER SAFETY and PREVENTING EQUIPMENT PROBLEMS. To help you recognize this information, we use the following terms to draw your attention to certain equipment labels and portions of this Service Bulletin. Please pay special attention to any label or information that is highlighted by one of these terms:

WARNING

Important information to alert you to a situation that might cause serious injury or death if instructions are not followed.

CAUTION





Important information that tells how to prevent damage to equipment, or how to avoid a situation that might cause minor injury.

Note

Information that you should pay special attention to.

WARNING

The following hazards may occur during the normal use of this equipment. Please read the following chart.

HAZARD	CAUSE	SAFEGUARDS
Fire 	Solvents and coatings can be highly flammable or combustible, especially when sprayed.	<ol style="list-style-type: none"> 1. Adequate exhaust must be provided to keep the air free of accumulations of flammable vapors. 2. Smoking must never be allowed in the spray area. 3. Fire extinguishing equipment must be present in the spray area.
Fire - Pressure Tank 	Vapors from flammable liquids can catch fire or explode.	<ol style="list-style-type: none"> 1. Keep tank at least 10 feet away from sources of ignition. Ignition sources include hot objects, mechanical sparks, and arcing (non-explosion proof) electrical equipment.
Inhaling Toxic Substances 	Certain materials may be harmful if inhaled, or if there is contact with the skin.	<ol style="list-style-type: none"> 1. Follow the requirements of the Material Safety Data Sheet supplied by your coating material manufacturer. 2. Adequate exhaust must be provided to keep the air free of accumulations of toxic materials. 3. Use a mask or respirator whenever there is a chance of inhaling sprayed materials. The mask must be compatible with the material being sprayed and its concentration. Equipment must be as prescribed by an industrial hygienist or safety expert, and be NIOSH approved.
Explosion, Pressure Tank - Rupture 	Making changes to pressure tank will weaken it.	<ol style="list-style-type: none"> 1. Never drill into, weld, or modify tank in any way. 2. Do not adjust, remove, or tamper with the safety valve. If replacement is necessary, use the same type and rating of valve.
Static Electricity 	Static electricity sparks may be created during the cleaning operation which may cause fire or explosion if not grounded properly.	To prevent sparks from static electricity, you must ground the Hose/Gun Cleaner, gun or tool attached to the fluid hose line from the equipment cleaner, and the waste container. Read Warning on Pg. 1.
General Safety	Improper operation or maintenance may create a hazard.	Operators should be given adequate training in the safe use and maintenance of the equipment (in accordance with the requirements of NFPA-33, Chapter 15 in U.S.). Users must comply with all local and national codes of practice and insurance company requirements governing ventilation, fire precautions, operation, maintenance and house keeping (in the U.S., these are OSHA Sections 1910.94 and 1910.107, and NFPA-33).

INSTALLATION INSTRUCTIONS

1. Insert liner into cup.

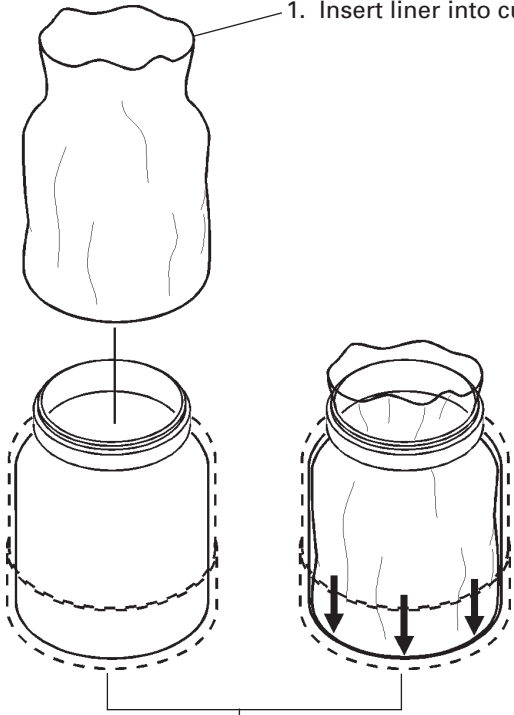

Step 1

2. Fill liner with coating.

3. Insert lid.

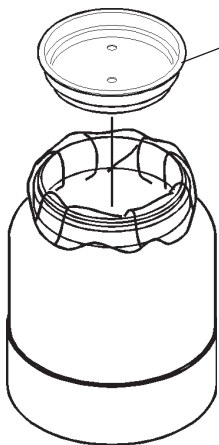

Step 2

4. Wrap liner over lid.

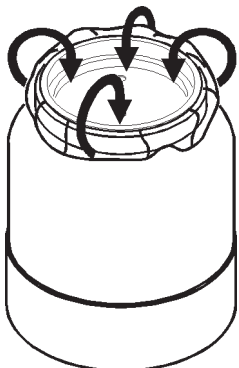

Step 3

5. Place ring inside lid.

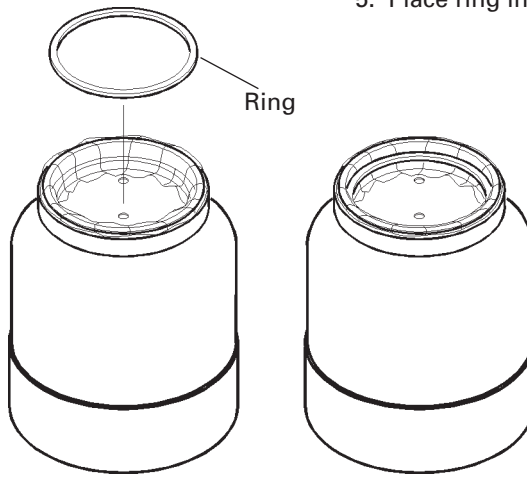

Step 4

6. Slide fluid tube through opening and assemble cup.

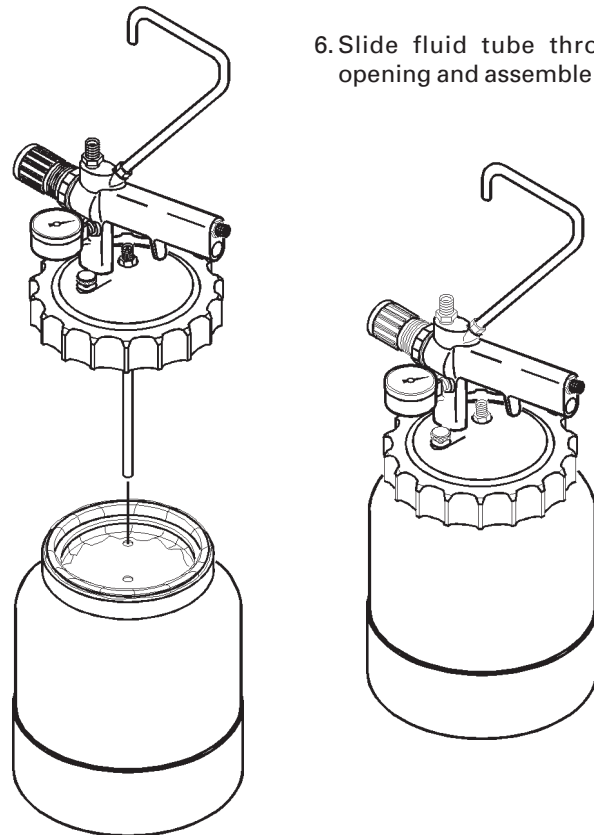

Step 5

DISASSEMBLY/CLEANING INSTRUCTIONS

1. Disassemble cup lid. Catch excess paint inside tube with a rag.

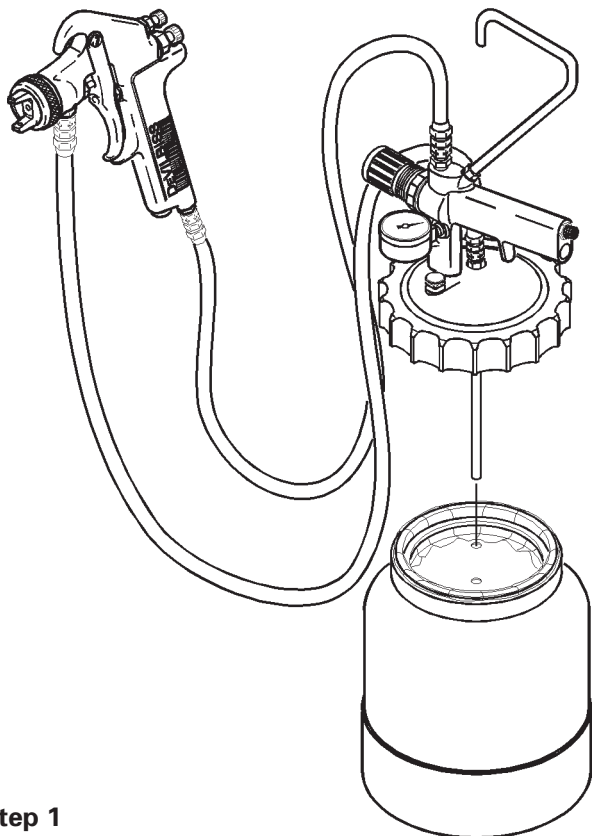

Step 1



WARNING

Extreme Explosion Hazard. Cup or waste container **must be grounded.** A static charge can build during flushing, potentially igniting the flammable vapors. Ground as shown in Step 2.

2. If you have Adapter Kit KK-5052, see SI-4-20-7 for further instructions. If not, proceed to Step 3.

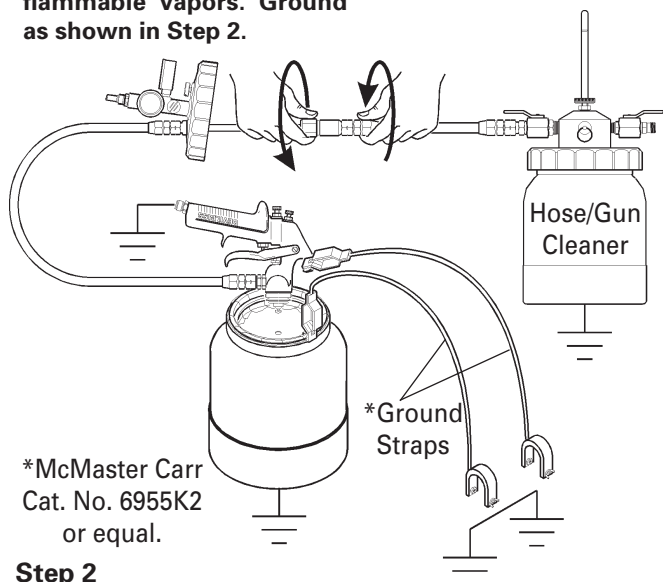

*McMaster Carr
Cat. No. 6955K2
or equal.

Step 2

3. Remove ring.

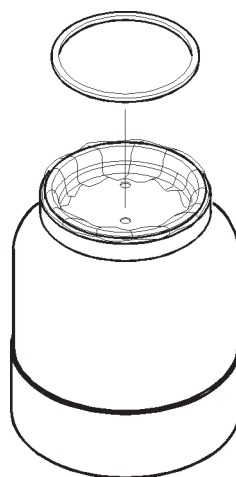

Step 3

4. Pull up on liner.

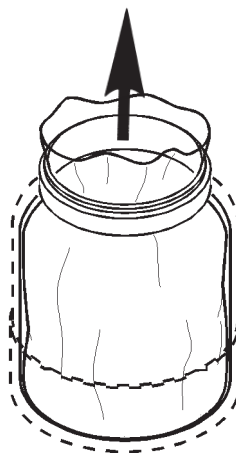

Step 4

5. Properly dispose of lid, liner and waste material. Save ring.

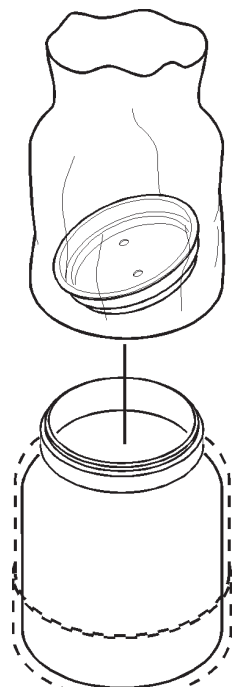

Step 5

NOTES

NOTES

WARRANTY POLICY

DeVilbiss products are covered by Finishing Brands one year materials and workmanship limited warranty. The use of any parts or accessories, from a source other than Finishing Brands, will void all warranties. For specific warranty information please contact the closest Finishing Brands location listed below.

Finishing Brands reserves the right to modify equipment specifications without prior notice. DeVilbiss, Ransburg, BGK, and Binks are registered trademarks of Finishing Brands. ©2014 Finishing Brands. All rights reserved.



DeVILBISS

DeVilbiss is part of Finishing Brands, a global leader in innovative spray finishing technologies. For technical assistance or to locate an authorized distributor, contact one of our international sales and customer support locations below.

USA/Canada

Industrial Finishing

www.devilbiss.com
info@finishingbrands.com
Tel: 1-800-992-4657
Fax: 1-888-246-5732

United Kingdom

www.finishingbrands.eu
info@finishingbrands.eu
Tel: +44 (0)1202 571 111
Fax: +44 (0)1202 573 488

China

www.finishingbrands.com.cn
mkt@finishingbrands.com.cn
Tel: +8621-3373 0108
Fax: +8621-3373 0308

Mexico

Industrial Finishing

www.finishingbrands.com.mx
sales@finishingbrands.com.mx
Tel: 011 52 55 5321 2300
Fax: 011 52 55 5310 4790

France

www.finishingbrands.eu
info@finishingbrands.eu
Tel: +33(0)475 75 27 00
Fax: +33(0)475 75 27 59

Japan

www.ransburg.co.jp
binks-devilbiss@ransburg.co.jp
Tel: 081 45 785 6421
Fax: 081 45 785 6517

Brazil

www.devilbiss.com.br
sales@devilbiss.com.br
Tel: +55 11 5641 2776
Fax: 55 11 5641 1256

Germany

www.finishingbrands.eu
info@finishingbrands.eu
Tel: +49 (0) 6074 403 1
Fax: +49 (0) 6074 403 281

Australia

www.finishingbrands.com.au
sales@finishingbrands.com.au
Tel: +61 (0) 2 8525 7555
Fax: +61 (0) 2 8525 7500

DeVILBISS
AUTOMOTIVE REFINISHING

DeVilbiss Automotive Refinishing is part of Finishing Brands, a global leader in innovative spray finishing technologies. For technical assistance or to locate an authorized distributor, contact one of our sales and customer support locations below.

USA/Canada

www.autorefinishdevilbiss.com
askus@devilbissar.com
Toll Free Tel: 1-800-445-3988
Toll Free Fax: 1-800-445-6643

Mexico

www.autorefinishdevilbiss.com.mx
Toll Free Tel: 1-888-835-6232 USA



DeVILBISS



Ransburg



BGK



BINKS



Finishing Brands